

CONTACTUM

Quality by design



DDB 250 Board Installation Instructions

Recommended Torque Settings

Connection Tightness

Ensure that the tightness of all electrical connections are checked and set to the recommended torque values as specified in [Table 1](#). *This includes all factory-fitted connections.*

Power Tool Warning

Do not use power tool screwdrivers for tightening electrical connections. Manual torque wrenches & screwdrivers must be used to ensure proper and safe tightening of terminations

Table 1

Termination	Recommended Torque (Nm)
Main Switch MCCB (Isolator)	12
RCD MCCB (Isolator)	12
MCB (busbar & Circuit Wiring)	2
RCBO - Busbar Connection	2
RCBO - Circuit Wiring	1.2
Main Incoming Earth Terminal	6.0
Outgoing Earth Terminals	2.5
Main Incoming Neutral Terminal	10
Outgoing Neutral Terminals	2.5
Busbar Link Terminals (M5 Bolt)	4

Installation Instructions

The Contactum DDB250 250A TP&N Distribution Board consists of a non-combustible enclosure, and includes the following components:

- Busbar Pan Assembly
- Neutral and Earth Terminal Bars
- Dead front cover with lockable door
- Removable Gland plates top and bottom
- Provision for SPD and Metering within the assembly.

Tested and certificated in accordance with BS EN 61439-3

The Distribution board has been designed to accommodate the following:

Incoming Isolating Devices (3P or 4P 250A Isolator, MCCB, or 4P 250A RCD MCCB) Outgoing Devices (MCBs, RCBOs & AFDDs)

SPDs & Metering components are designed to be installed within the board.

Installation Instructions for Contactum DDB250 Enclosure

Removing the Front Cover

Open the door and remove the lid fixing screws. (Refer to [Figure 1](#) for guidance.)

Preparing the Enclosure

To prevent swarf and debris from entering the unit, always remove the gland plate before cutting cable and trunking entries. ([Figure 1](#))

Mounting the Base

Using the dimensions provided in [Figure 2](#), fix the base of the enclosure securely to the wall using the appropriate screws.

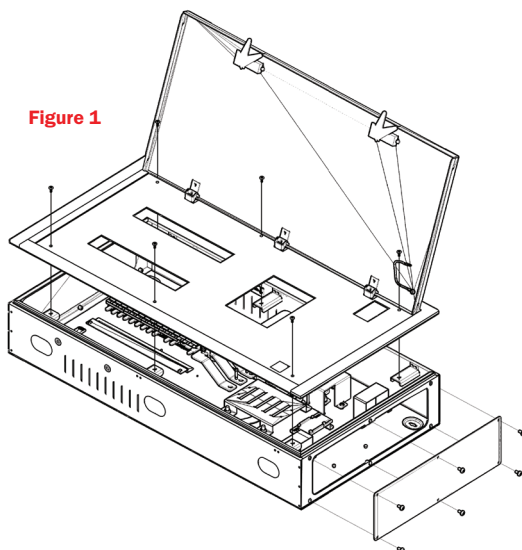

Figure 1

Important Installation Requirements

The installation of the Contactum DDB250 Board must be performed by a qualified registered electrician. The work must be carried out in accordance with the current edition of the IET Wiring Regulations, BS7671 – Requirements for Electrical Installations.

Power Isolation & Safety Precautions

Before beginning installation or maintenance work on the DDB250 Board, ensure the power supply to the unit is switched off and verified to be dead.

IMPORTANT: Configuration for 4-Pole Incoming Devices

When installing a 4-pole device, the board must be reconfigured from a 3-pole to a 4-pole setup. Ensure all necessary modifications are made to accommodate the 4-pole device before installing the board to the wall.

Fixing hole dimensions:

No of ways	DIM A	DIM L
06W	705	799
08W	759	853
10W	813	907
12W	867	961
16W	975	1069
20W	1083	1177
24W	1191	1285

Figure 2

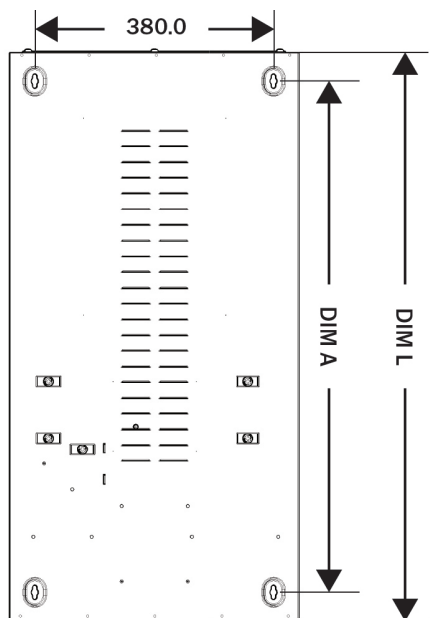

Installation of Isolating Device (See Figure 3)

The pan assembly is designed to mount selected Contactum isolating devices, including:

3-pole or 4-pole 250A MCCB, or 250A 4-pole MCCB RCD.

Installing a 3-Pole MCCB Isolator

Remove busbar cover (Figure 3.1)

Ensure that the busbar links are properly aligned with the terminals on the MCCB. (Figure 3.2)

Use the screws provided to securely fasten the MCCB to the panel. (Figure 3.3)

Tighten the busbar links to the MCCB using the bolts supplied. Ensure that the connections are tightened to the recommended torque values listed in Table 1.

IMPORTANT: Configuration for 4-Pole Incoming Devices

When installing a 4-pole device, the board must be reconfigured from a 3-pole to a 4-pole setup. Ensure all necessary modifications are made to accommodate the 4-pole device before installing the board to the wall. See 3-4-pole conversion instructions below.

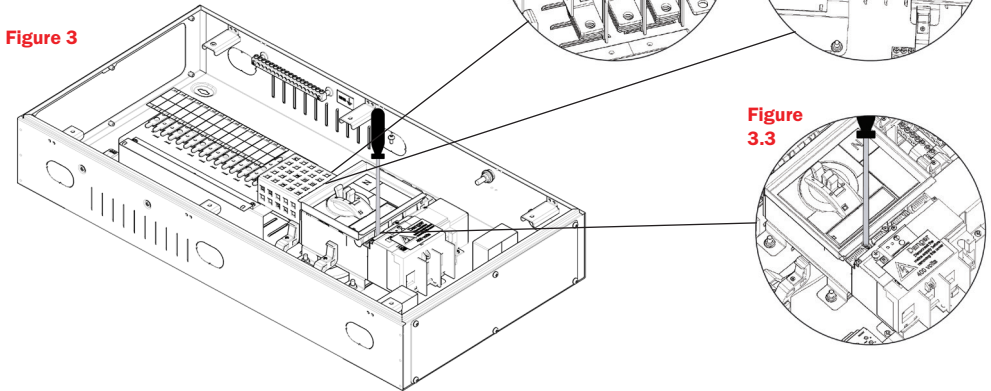

Installation of outgoing MCBs (See Figure 4)

Ensure the power supply is switched off before beginning the installation process.

Ensure all MCB terminal screws are fully open to allow for proper connection.

Push the MCB onto the appropriate outgoing busbar way. (Figure 4.1)

Ensure that the busbar stub enters the bottom cage of the MCB and that the DIN clip is facing towards the busbar assembly (Refer to Figure 4.2 for proper alignment).

Tighten the busbar connections using the recommended torque settings specified in Table 1.

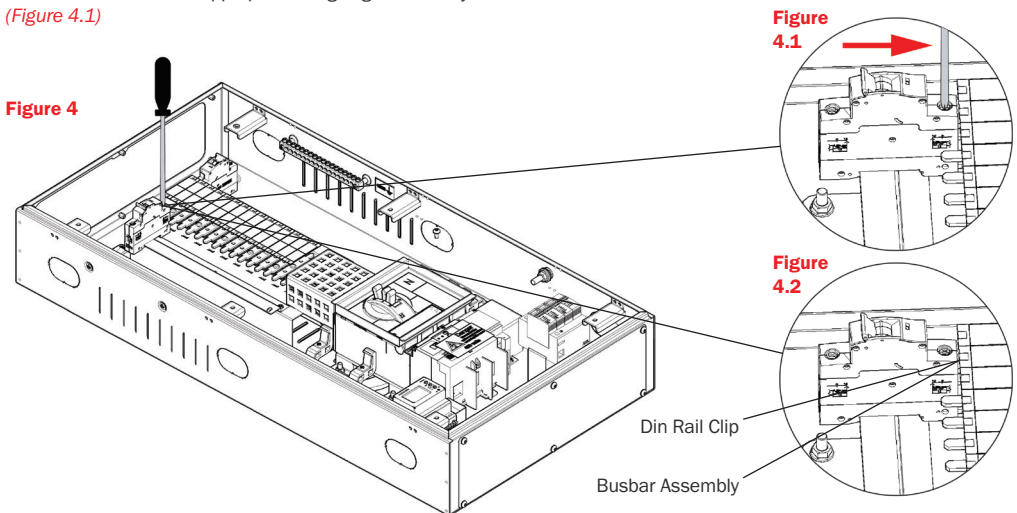

Installation of outgoing RCBOs (See Figure 5)

Ensure the power supply is switched off before starting the installation.

Ensure all RCBO terminal screws are fully open to allow for proper connection.

Push the RCBO onto the appropriate outgoing busbar way.

Ensure that the busbar stub enters the bottom cage of the RCBO and that the DIN clip is facing towards the busbar assembly.

Tighten the busbar connections using the recommended torque settings specified in *Table 1 (Refer to Figure 5.1 for reference)*.

Connect the RCBO neutral lead to the appropriate numbered terminal on the neutral terminal bar (*Refer to Figure 5.2 for correct placement*).

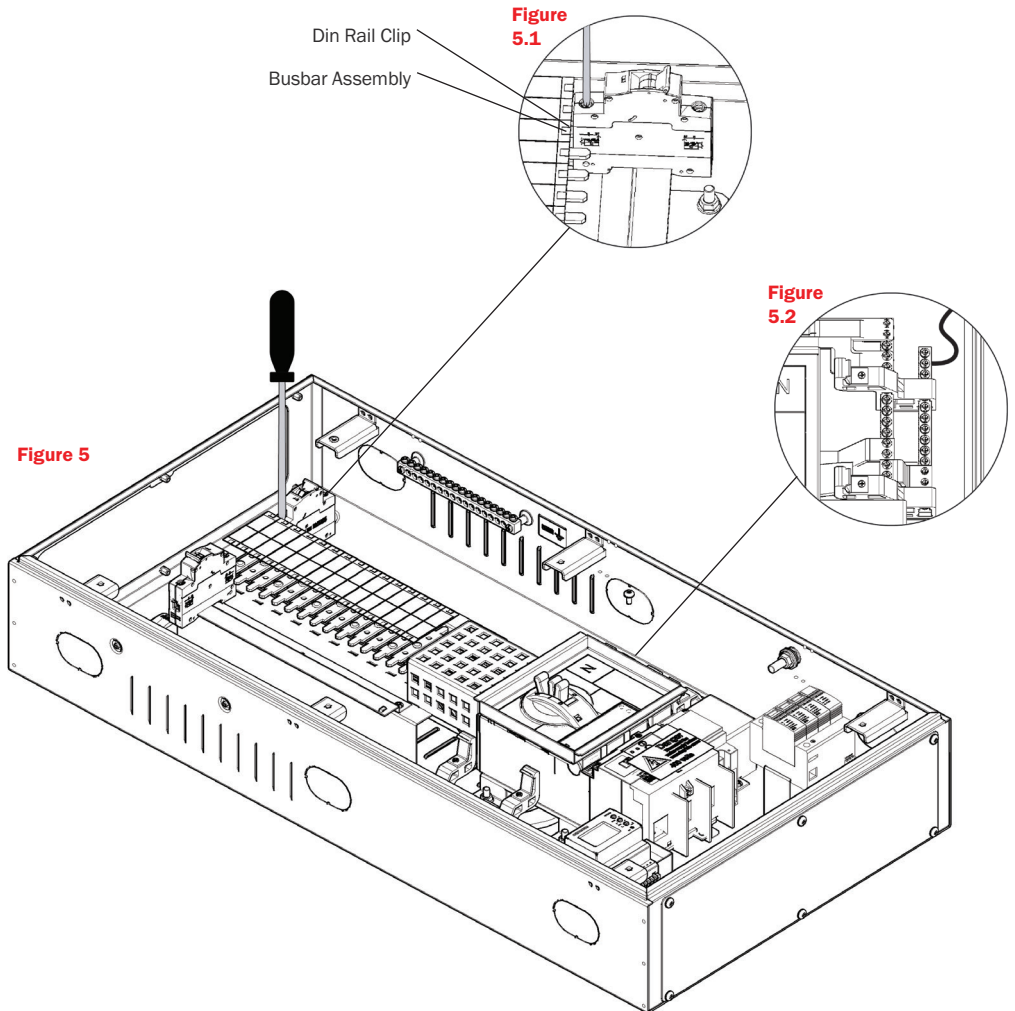

3-Pole to 4-Pole Conversion

Before installing the board to the wall, the following steps must be completed:

Remove the shrouds covering the neutral terminals and the main neutral assemblies. (Figure 6.1)

Disconnect the main neutral assembly from the neutral bar by removing the 2 terminal screws. Keep the screws safe as they will need to be reinstated later. (Figure 7.1)

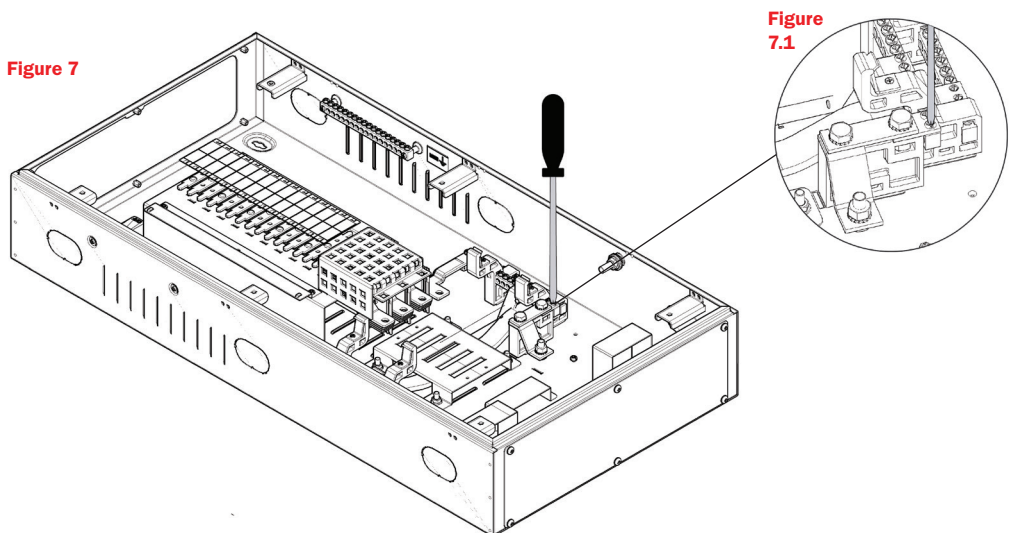
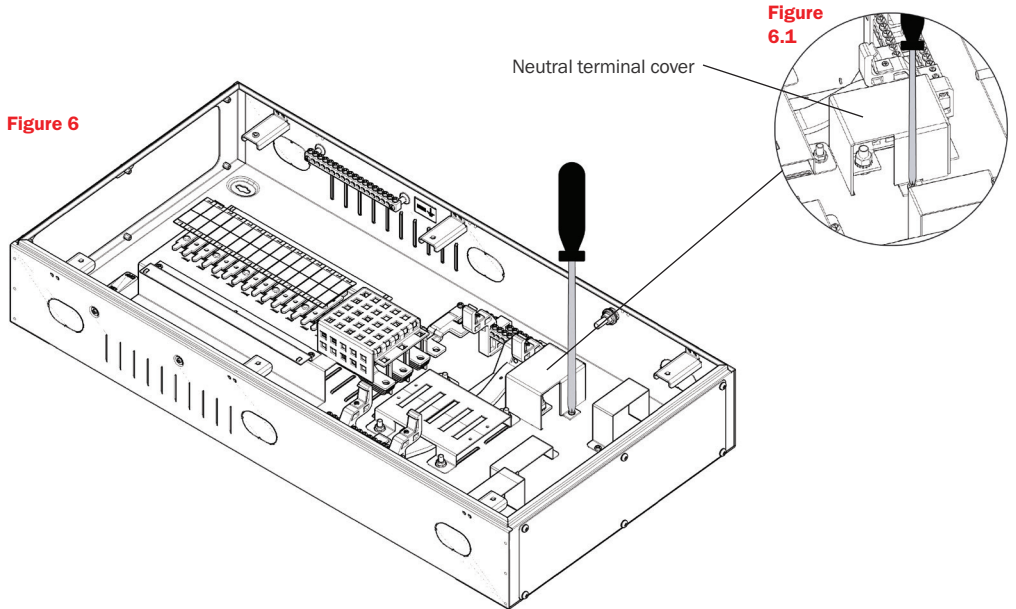

3-Pole to 4-Pole Conversion (Continued)

Access the rear of the unit.

Loosen and remove the bolt securing the main neutral assembly. (Figure 8.1)

Carefully remove the main neutral assembly. (Figure 9.1)

Re-secure the bolt back in place to the assembly.

Store this entire assembly safely as it may be needed in the future.

Figure 8

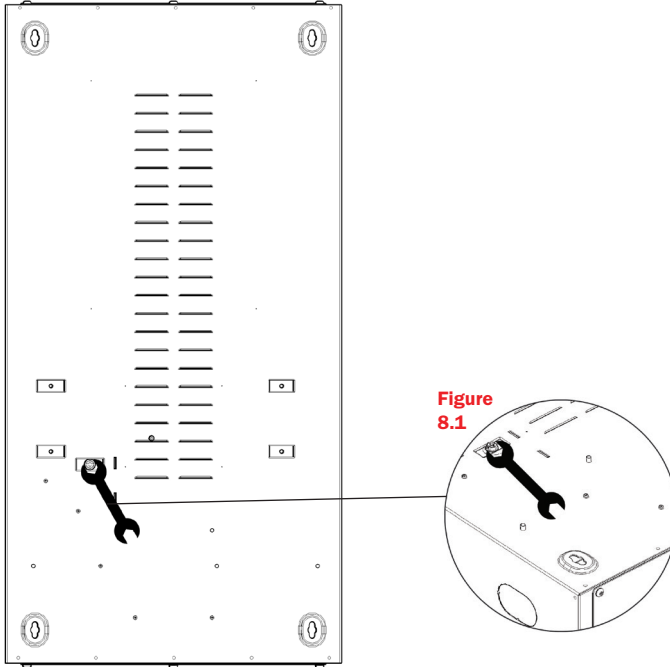
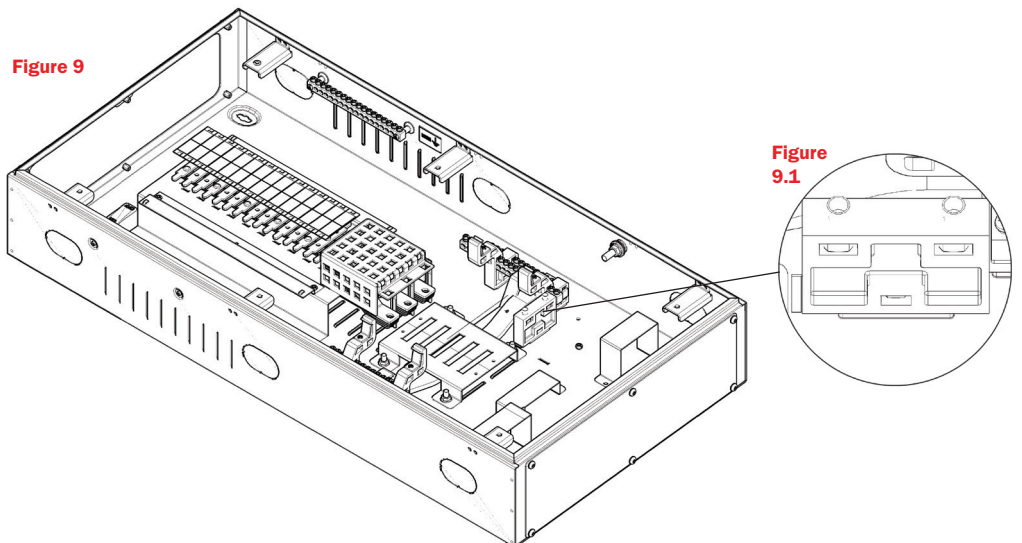

Figure 9



3-Pole to 4-Pole Conversion (Continued)

Lay the board on its rear to gain access to the necessary internal components.

Return the 2 previously removed screws to the neutral bar.

Install the appropriate 4-pole incomer. Ensure the neutral terminal is positioned correctly on the right-hand side (RHS). Make sure the phase busbar links are positioned correctly.

Securely install the MCCB to the pan assembly using the screws provided with the device.

Remove the 2 top screws of the RHS neutral bar.

Install the provided neutral connecting link to the top of the neutral terminal bar. Ensure the neutral link is correctly oriented in the MCCB neutral terminal. (Figure 10.1)

Install the termination bolts to connect all busbar links to the MCCB. Ensure that the recommended torque values from Table 1 are followed.

Replace and tighten the terminal bar screws onto the neutral bar, ensuring that the correct torque values from Table 1 are respected.

Replace the busbar shroud above the MCCB once installation is complete.

Neutral shrouds must be replaced after completing the outgoing circuit neutral terminations.

Lastly, prepare the DFC by gently removing the breakout with pliers. This will create a gap for the 4-pole breaker to sit in, allowing the front cover to be refitted.

Figure 10

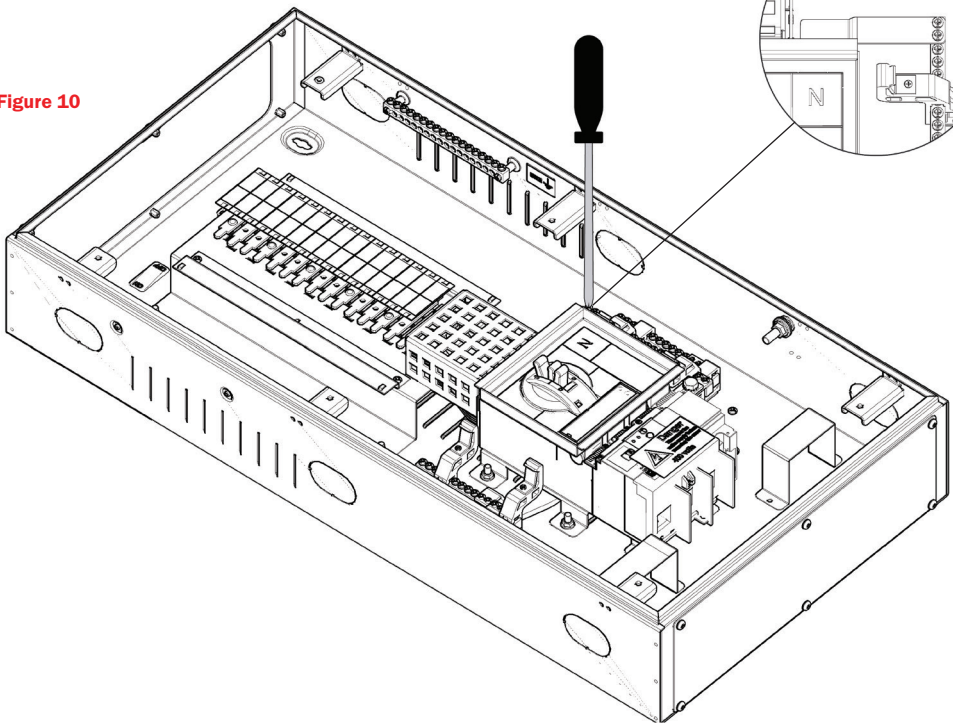
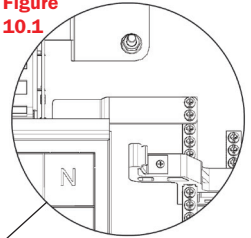

Figure 10.1



CONTACTUM

www.contactum.co.uk
020 8208 7419
sales@contactum.co.uk

18 Eyncourt Road,
Woodside Estate,
Dunstable



Scan me for more
info on our website



@ContactumLtd



Contactum Ltd



@ContactumLtd



@ContactumLtd



Contactum Ltd



1300417 - Rev 0