

Intelligent Dimmers

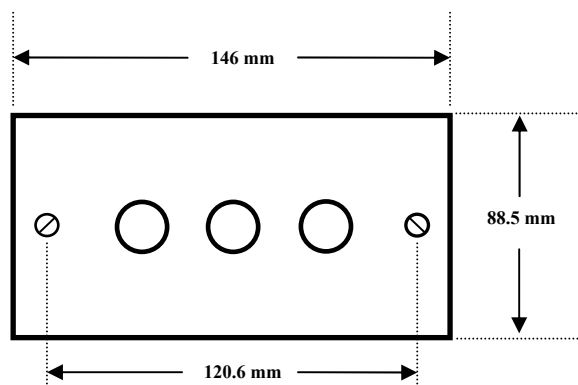
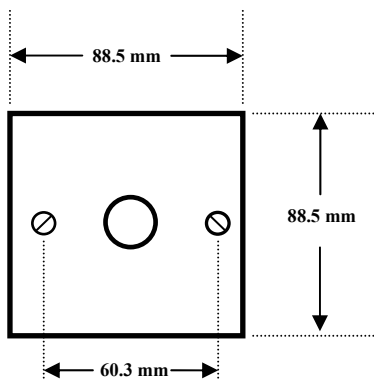

Technical Specifications

Voltage

- Typically 230V a.c 50Hz

Wattage

- 250W, 400W and 500W available (equates to 200VA, 320VA and 400VA)

Switching type

- All Intelligent dimmers are two way

Standards

- Manufactured to BSEN 60669-2 & BSEN 55015 standards where applicable

De-rating

- Please de-rate by 20% for Low Voltage lighting and by 50% when used with Mains halogen lighting

Wall box

- Minimum wall box depth of 25 mm, 35 mm recommended (wall box to BS 4662 standards)

Guarantee

- All Intelligent dimmers are guaranteed for 3 years from date of manufacture

GUIDELINES FOR INSTALLATION

Safety Instructions

- Before starting any work, ensure that you read and fully understand this literature sheet.
- Ensure that mains supply has been isolated before commencing installation.

! IF IN ANY DOUBT CONSULT A QUALIFIED ELECTRICIAN !

Wiring Diagram

NOTE: This dimmer switch uses a leading edge principle and **cannot** be used in applications that require hard fired (trailing edge) dimmers. It is quite normal for a slight buzzing to be heard from the dimmer switch in normal operation.

